

SERIE XBG

CODICE DI ORDINAZIONE / DECODING

3.1.55 . XXX . 0 . P . 0 . 0

CILINDRATA/DISPLACEMENT

CODICE BASE/BASIC CODE

3.1.55.

DIN
5 4 6 2
SE

XBG 122

Pompa ad Ingranaggi
Gear Pump



New

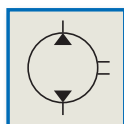

CARATTERISTICHE E DATI TECNICI / SPECIFICATIONS AND TECHNICAL DATA

TIPO TYPE	CODICE CODE	CILINDRATA DISPLACEMENT cm ³ /rev.	A mm	B mm	C ASPIRAZIONE/MANDATA INLET/OUTLET	PESO WEIGHT kg
--------------	----------------	---	---------	---------	--	----------------------

XBG 122	3.1.55.122.0.P.0.0	119.2	141	239	1" 1/4 G	22.9
---------	--------------------	-------	-----	-----	----------	------

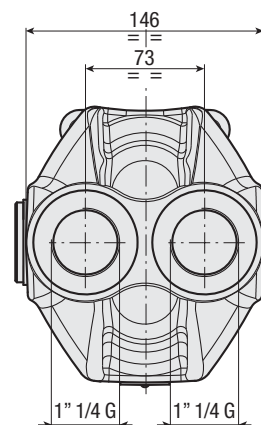
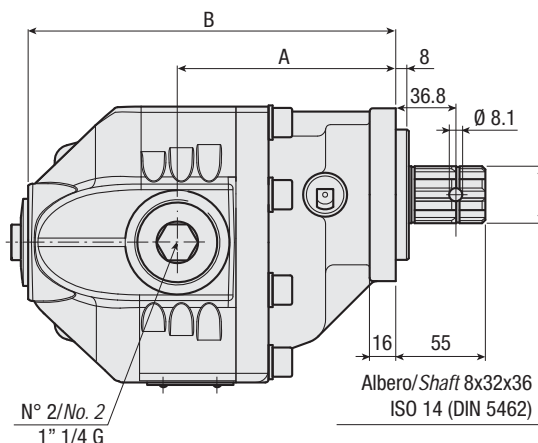
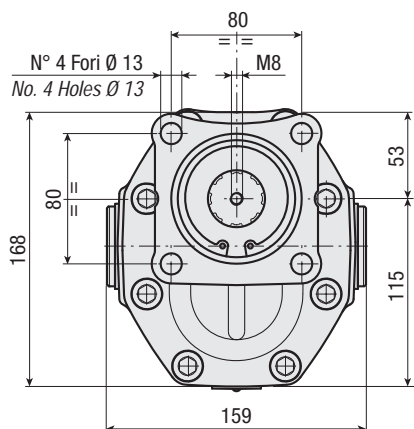

DATI TECNICI / TECHNICAL DATA

ESEMPIO CICLI LAVORO / EXAMPLE OF WORKING CYCLES

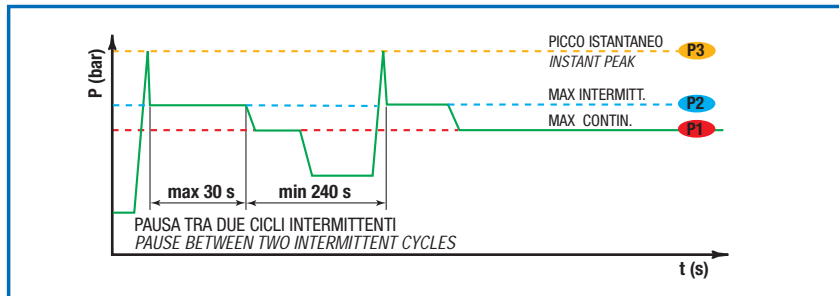

Pressione d'aspirazione: Inlet pressure:	0.7 ÷ 1.5 bar (assoluti/absolute)
Campo viscosità lavoro: Operating viscosity range:	12 ÷ 100 cSt
Temperatura fluido °C (t): Fluid temperature °C (t):	-10° + 80° C

Pressione Lavoro Working Press. P2	Contaminazione / Contamination		Filtro / Filter $\beta_x = 75$
	NAS 1638	ISO 4406	
≤ 200 bar	12	21/18	40 μ m
≥ 200 bar	11	20/17	25 μ m

◀ **FILTRAZIONE CONSIGLIATA (ritorno o mandata)**
RECOMMENDED FILTERING (return or outlet)

TIPO / TYPE			Vg	cm ³ /n cm ³ /rev.	bar	n/min r.p.m.
Cilindrata Displacement						
Pressione massima continua Max continuous operating pressure		P1				
Pressione massima intermittente Max intermitt. operat. press.	(max 30 s)	P2				
Pressione massima di picco Max peak pressure	(≤ 0.1 s)	P3				
Velocità massima intermittente Max intermittent speed	(P ≤ 20 bar)	n3				
Velocità massima continua Max continuous speed	(≤ P1)	n1				
Velocità minima intermittente Min intermittent speed	(≤ P2 x 0.5) (max 30 s)	n4				

XBG 122
119.2
210
230
245
2000
1500
300

DIAGRAMMI / DIAGRAMS

RILIEVI ESEGUITI CON OLIO ISO VG 46 A 50° C ($\nu = 30$ cSt)
THE ABOVE SPECIFICATIONS REFER TO OIL TYPE ISO VG 46 AT 50° C ($\nu = 30$ cSt)

POTENZA ASSORBITA / ABSORBED POWER

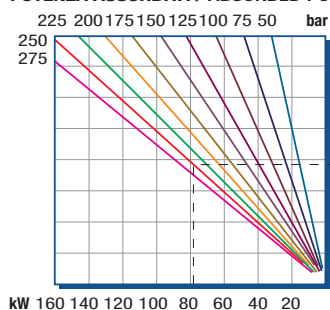

PORTATA / CAPACITY

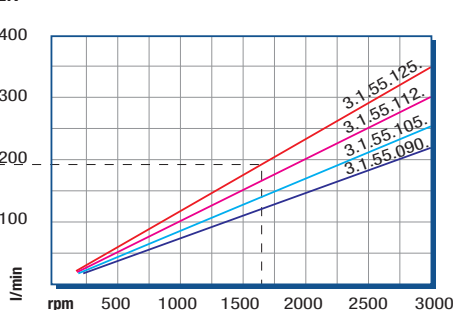

COPPIA ASSORBITA / INPUT TORQUE

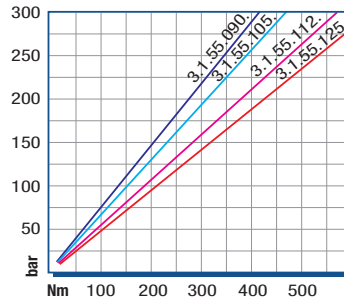

ROTAZIONE POMPA / PUMP ROTATION

