

TANDEM DIN 5462 SE

CODICE DI ORDINAZIONE / ORDERING CODE

200 FZH XXX X V

TIPO / TYPE
 POMPA AD INGRANAGGI / GEAR PUMP

CILINDRATA / DISPLACEMENT

DIN 5462 SE
 ROTAZIONE / ROTATION
D = DESTRO / CLOCKWISE
S = SINISTRO / ANTICLOCKWISE

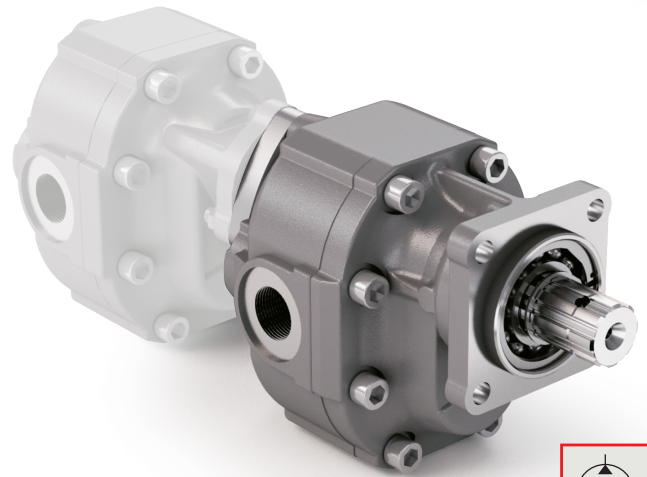

FZH 116 V

1

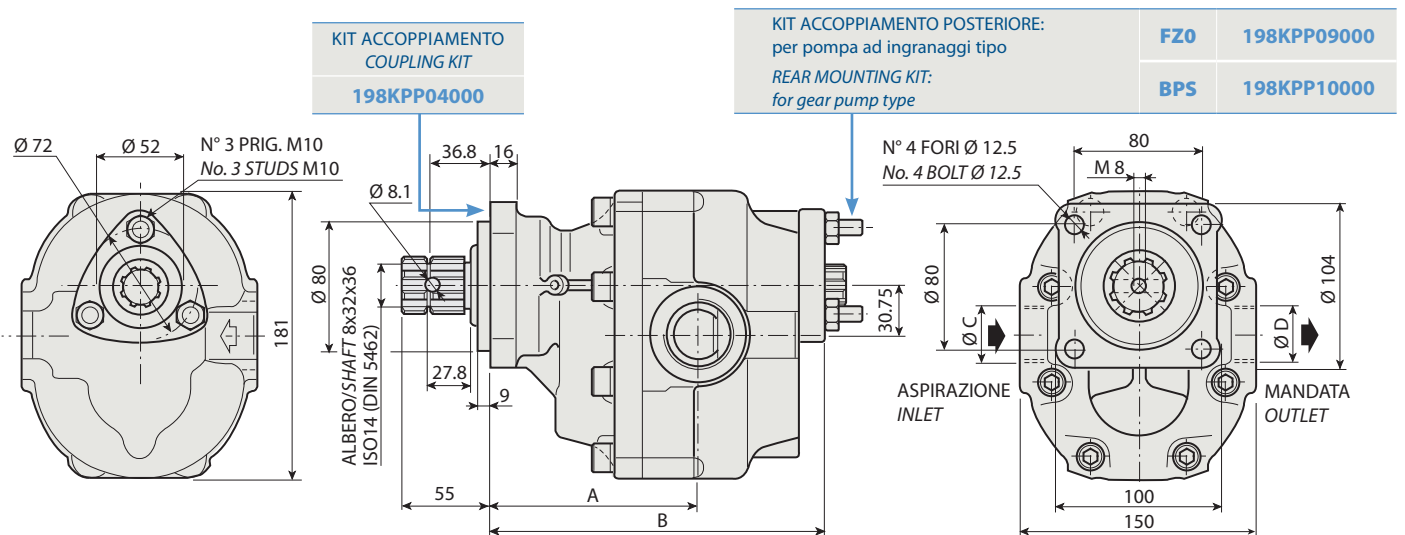

CARATTERISTICHE E DATI TECNICI / SPECIFICATIONS AND TECHNICAL DATA

TIPO / TYPE	CODICE / CODE		CILINDRATA / DISPLACEMENT	A mm	B mm	C ASPIRAZIONE / INLET	D MANDATA / OUTLET	PESO / WEIGHT
	ROTAZIONE DESTRA / CLOCKWISE ROT.	ROTAZIONE SINISTRA / ANTICLOCKWISE ROT.	cm ³ /rev.					kg

FZH 116 V	200FZH116DV	200FZH116SV	116	139.5	221	1" ¼ G	1" G	21.2
------------------	--------------------	--------------------	------------	--------------	------------	---------------	-------------	-------------

KIT RASAMENTI / THRUST PLATES KIT CODICE / CODE 2H451075000

KIT GUARNIZIONI COMPLETO / COMPLETE SEALS KIT CODICE / CODE 21901500000

Per la scelta dei raccordi orientabili vedi pag. 212-213 / For the selection of adjustable fittings see page 212-213

- A richiesta possono essere fornite le pompe ad ingranaggi con le guarnizioni HNBR per climi freddi (-40 °C).
- On request our gear pumps may be supplied with HNBR seals for cold climates (-40 °C).

TANDEM DIN 5462 SE

TIPO / TYPE		
Cilindrata <i>Displacement</i>	Vg	cm ³ /n cm ³ /rev.
Pressione massima continua <i>Max continuous operating pressure</i>	P1	bar
Pressione massima intermittente <i>Max intermittent operating pressure</i>	(max 30 s) P2	
Pressione massima di picco <i>Max peak pressure</i>	(≤ 0.1 s) P3	
Velocità massima intermittente <i>Max intermittent speed</i>	(P ≤ 20 bar) n3	n/min r.p.m.
Velocità massima continua <i>Max continuous speed</i>	(≤ P1) n1	
Velocità minima intermittente <i>Min intermittent speed</i>	(≤ P2 x 0.5) (max 30 s) n4	

FZH 116 V

116
250
280
340
3000
1500
250

DIAGRAMMI / DIAGRAMS

POTENZA ASSORBITA
POWER INPUT

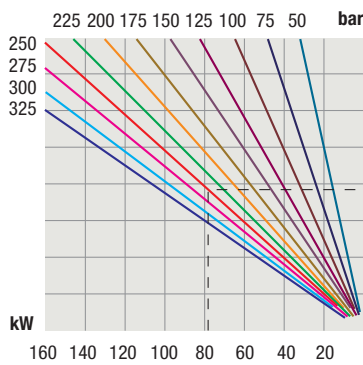

PORTATA
CAPACITY

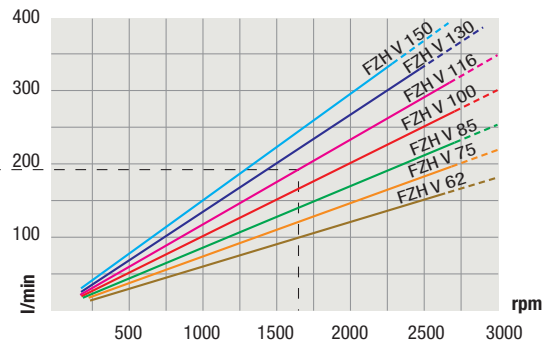

RENDIMENTO VOLUMETRICO
VOLUMETRIC EFFICIENCY

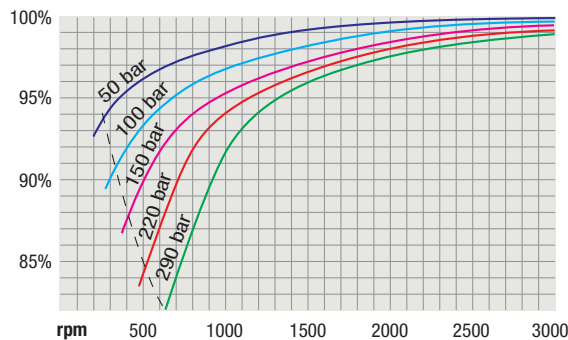

COPPIA ASSORBITA
DRIVE TORQUE

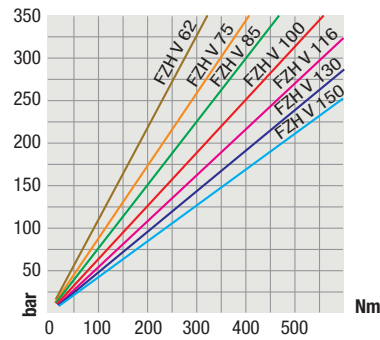

RILIEVI ESEGUITI CON OLIO ISO VG 46 A 50° C ($\nu = 30$ cSt)
THE ABOVE SPECIFICATIONS REFER TO OIL TYPE ISO VG 46 AT 50° C ($\nu = 30$ cSt)